

WIND TO HYDROGEN

Science Education Kit

Assembly Guide



Model No.: FCJJ-56

Warning

To avoid the risk of property damage, serious injury or death:

This kit should only be used by persons 14 years old and up, and only under the supervision of adults who have familiarized themselves with the safety measures described in the kit. Keep small children and animals away, as it contains small parts that could be swallowed. Read the instructions before use and have them ready for reference.

Battery operation instructions:

1. The removing and inserting of batteries is to be conducted by the adults only. Unscrew the screw holding the battery pack's cover in place using a screw driver. Once the screw is removed open the battery pack and take out the batteries using your fingers. Do not use a metal object. When inserting the batteries make sure that you are doing so with the correct polarity (the positive end of the battery must match up with the "+" and the negative end of the battery must match up with the "-" indicated on the battery pack), close the battery pack and secure its cover by tightening the screw with a screw driver.
2. Non-rechargeable batteries are not to be recharged.
3. Different types of batteries such as rechargeable, alkaline and standard batteries or new and used batteries are not to be mixed and should be used separately.
4. The battery pack cables are not to be inserted into an AC socket.
5. The supply terminals of the battery pack are not to be short-circuited.
6. The two spare red & black cables are not to be inserted into an AC socket.
7. Exhausted batteries are to be removed from the battery pack.

Wind to Hydrogen Education Kit

ASSEMBLY GUIDE

What you need: ● WTHSEK ● AA batteries=2 Units ● Water=100ml ● Scissors

IMPORTANT: Use common sense when connecting the parts described in this guide. Improper connections can cause failure and permanent damage to your equipment.

Assembly of the Wind Turbine:

- Please refer to the Wind Energy Energy Kit Assembly Instructions included in your Kit for reference in assembling the Wind Turbine.
- Below table indicates expected RPM speed, current, voltage, and power when placing the WindPitch in constant windspeed of 10mph when connected to load of 50 Ohms. This level of resistance may be applied using common potentiometer (not provided) or Horizon's variable resistor module (included in Renewable Energy Science Education Kit- FCJJ-37)

Wind Kit Technical Specifications:

Blade Type	No. of Blade	Wind Speed (mph)	Load (Ohm)	Output Voltage (V)	Output Current (mA)	Output Power (W)	Rotor Speed (RPM)
A	3	10	50	1.15	28	0.03	400
B	3	10	50	1.35	30	0.04	490
C	3	10	50	2.50	50	0.125	705

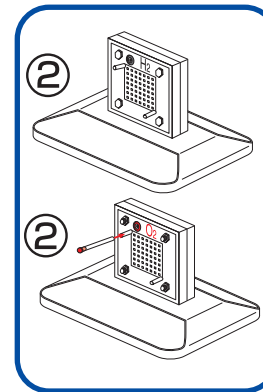
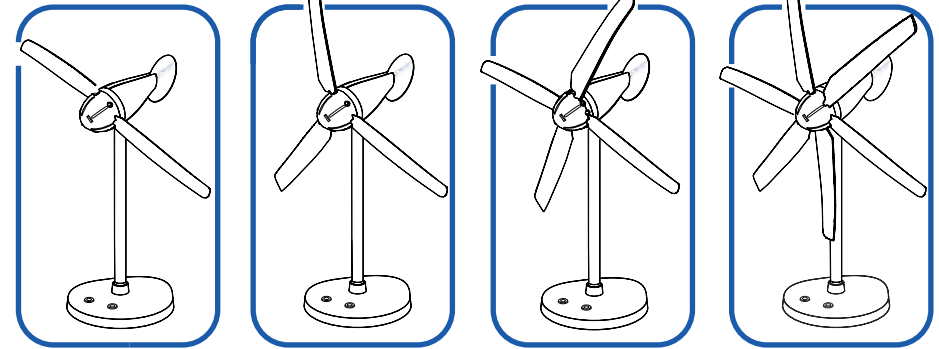

Preparation of the Electrolyzer Module and Wind Powered Hydrogen Production

2. Insert the reversible fuel cell, terminals on top, into the slot on the base. Cut 2 x 4cm length pieces of rubber tube and insert a black pin into the end of one tube. Place the tube with the black pin into the top pin on the hydrogen side (with black terminal). Place the other tube firmly onto the top input nozzle on the oxygen side.
3. Fill the syringe with DISTILLED water. On the red oxygen side of the electrolyzer, connect the syringe to the uncapped tube. Fill the reversible fuel cell until water begins to flow out of the tube. Attach a red plug to the Oxygen side tube. Let settle for 3 min.
4. Attach the round cylinders to the cylinder base by pressing downward into round slots and twisting into place. Then add water up to the "0" line.

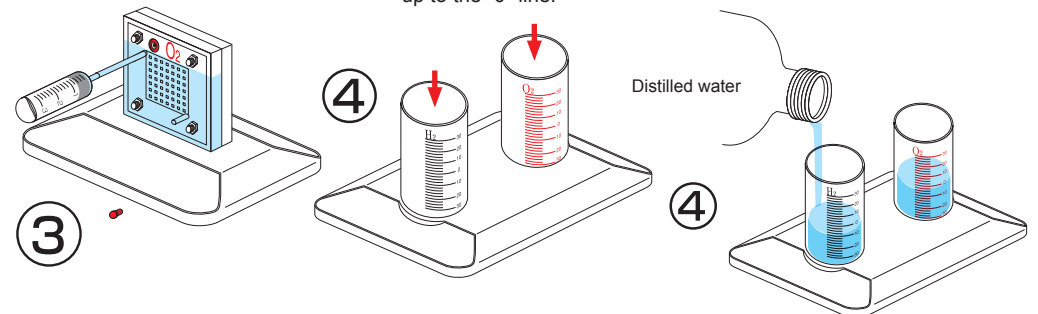

5. Place inner containers into outer cylinders minding that the gaps are not blocked by inner plastic rims. Make sure the water is still level to the "0" line. If not, remove some water with the syringe so that water level is at "0" line. Cut the remaining piece of long tubing into two pieces of approximately 20 cm length. Connect the two pieces of tubing to the top nozzles on the inner containers. If the tubing is connected to the inner cylinders last there will be no air trapped inside the inner containers.

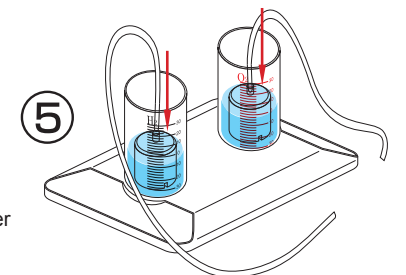

6. Connect the other end of the long tube on the hydrogen side to the bottom end of the black hydrogen side of the reversible fuel cell. Connect the other end of the long tube on the oxygen side to the bottom end of the red oxygen side of the reversible fuel cell.

7. Connect the red and black cables to the corresponding terminals located on the wind turbine and reversible fuel cell. For best results using the WindPitch to generate hydrogen using the included reversible fuel cell, setup the wind turbine hub with 3 profiled blades makred C supplied with the kit.

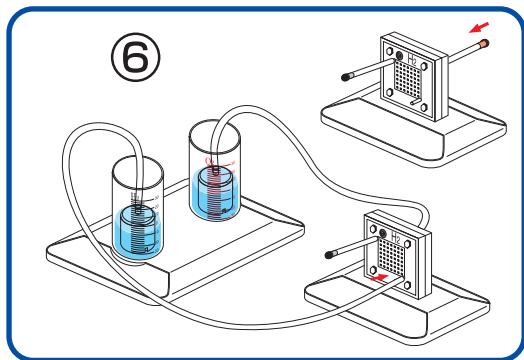

Set the blade pitch to 6 degrees. Make sure that the wind turbine is generating AT LEAST 2.5 volts. If not, move the wind turbine closer to the fan until it does. The wind turbine is sensitive to this setting at high wind speeds.

Allow the table fan and wind turbine to run for about 60 minutes on high wind speed setting to generate sufficient amounts of hydrogen and oxygen gases that are stored in the water/gas tanks.

If the wind is sufficient the system will now start to produce hydrogen and oxygen in the respective cylinders. When bubbles begin to surface in the hydrogen cylinder the cycle is complete. Disconnect the reversible fuel cell from the Wind Turbine.

Procedure for repeated gas production: Disconnect the small plugs from the tubes connected to the nozzles on the reversible fuel cell. This will allow water into the inner cylinders to replace the gasses and reset water levels to "0" line. Re-insert the plugs into the tubes and repeat electrolysis again.

Note: You may also use the battery pack to perform electrolysis (In the case of no wind source)

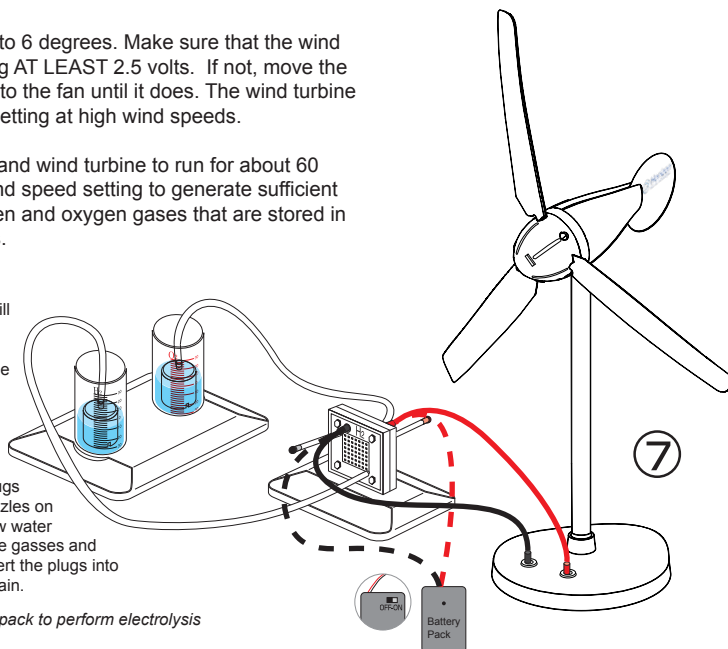

Using the Battery Pack to Perform Electrolysis (in the case of no wind)

Please remove the screw from cover of battery box using a screw driver. Push and slide the cover and open the battery box. Try NOT to touch the cables when you open the cover. Place two AA batteries as indicated. Push and slide the battery box cover to closed position and screw tightly into place using screw driver.

- ✘ Make sure the switch on the battery box is in the "off" position before you place the batteries into the box.
- ✘ **WARNING:** If the cable is short circuited the batteries inside could become hot and potentially cause burns, melting of parts, or create risk of fire.
- ✘ Note: Battery's energy may be consumed after 4-5 times of use.

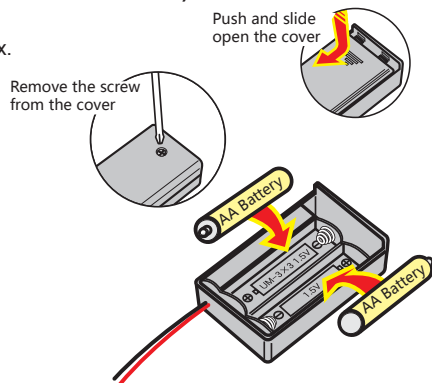

Using the Reversible Fuel Cell to Power a Small Motor with Fan Blade

8. **Assembly of the small electric fan:**
Connect small round white adapter to the motor axis. Connect the fan blade to the adapter.

9. Connect the motor with electric fan to the reversible fuel cell using the cables as shown. The motor should begin to turn and consume the hydrogen fuel stored in the cylinders. The fan may need to be flicked with your finger to start.

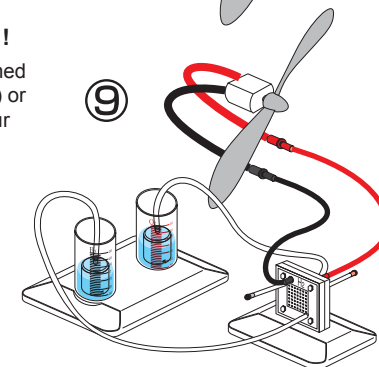
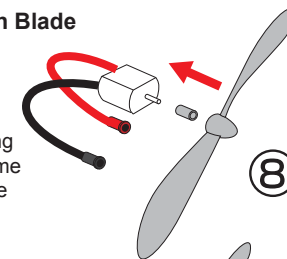

Take your WindPitch experimentation to the next level !

Listed below are additional wind experiments that can be performed with the WindPitch wind turbine using a multimeter (not provided) or with Horizon's Renewable Energy Monitor (not provided) and your computer. Please refer to the experiments section located on the Horizon Renewable Energy Curriculum CD.

- **Using Different Blade Shapes Create Power**

This experiment demonstrates how blades with different curvatures produce different degrees of power output. Wind turbine blades are shaped like airplane wings, and one size does not fit all requirements. You will measure and understand how using the right blade shape can produce optimum power for different wind conditions.

- **How Many Blades Are Best? 1, 2, 3, 4...**

Using the right number of blades for a given wind condition is important in extracting the maximum electrical power from a wind turbine. You will measure and understand the choices between the numbers of blades that are necessary to produce best results.

- **Adjusting Blade Pitch for Best Performance**

Angling the blades into and away from the wind are important elements in creating maximum power – or slowing the speed of rotation. This experiment will show you the techniques for stalling and furling as well as adjusting the blade pitch to extract the maximum degree of

- **How Much Power Can Be Extracted from the Wind**

While power from the wind is free as long as it blows, it is still limited to certain physical laws. This experiment will show you how to measure wind speed versus extracted wind power.

- **Using Wind Power to Generate Hydrogen**

One important use of wind power is to generate hydrogen in a clean, non-polluting manner. This experiment shows you exactly how to do it.

- **Measure Wind Turbine Performance Using RPM**

Using our electronic measurement tool you can measure the voltage, current, power and RPM (revolutions per minute) rotational speed of the wind turbine and see it displayed on the measurement tool as well as your computer. Watch the RPM as it changes with wind speed and resistor loading and witness how to slow down and even stop the wind turbine spinning without even touching it – just by adding the right resistor combinations. Make measurements for wind power and turbine efficiency to really understand how this remarkable device works.

- **Build a Wind Farm**

Arrange multiple WindPitch turbines in series and parallel configurations in order to study the voltage, current, and power generated. Design a simulation of a commercial wind farm in model scale and learn the potential of wind power as a mass energy source.

WIND TO HYDROGEN SCIENCE EDUCATION KIT

TECHNICAL SUPPORT

1. The water levels do not drop when the gas outlet tubes on both sides of the fuel cell are unplugged.

Solution:

Check whether the holes on the wall of the inner cylinder are blocked. If so, turn the inner cylinder until water enters the holes and fills up the inner cylinder.

2. The reversible fuel cell does not produce hydrogen and/or oxygen.

Solution 1:

Check whether the wires are appropriately connected, and whether there are any loose connections. The fuel cell could be completely destroyed if the red wire of the battery pack is connected to the blackjack of the fuel cell.

Solution 2:

Make sure the batteries are inserted with the correct polarity.

Solution 3:

Replace the old batteries with new one in the battery pack.

3. The water electrolysis process slows down.

Solution 1:

Inject water to the oxygen side of the reversible fuel cell by using the syringe and wait for about 3minutes.

Solution 2:

Replace the old batteries with new one in the battery pack.

4. The motor does not run while there is hydrogen left in the inner container.

Solution:

Unplug the black pin of the short tube on the reversible fuel cell and quickly attach the pin back to the tube to purge out impure gases. You should then see the motor beging to turn again.

5. No hydrogen is produced using the wind turbine outdoors.

Solution:

If the wind speed is not sufficient electricity will not be created. Use a common desk fan with faster wind speed to perform the electrolysis using the reversible fuel cell, or conduct the experiment under sufficient wind conditions.

If you have any further issues contact support@horizoneducational.com